



# SENTRY™

## LOCKING STORAGE DASH

MADE IN THE  
★USA★  
WITH PRIDE

E-Z-GO® TXT® /  
DOUBLETAKE® PHOENIX-TX™ & TITAN™

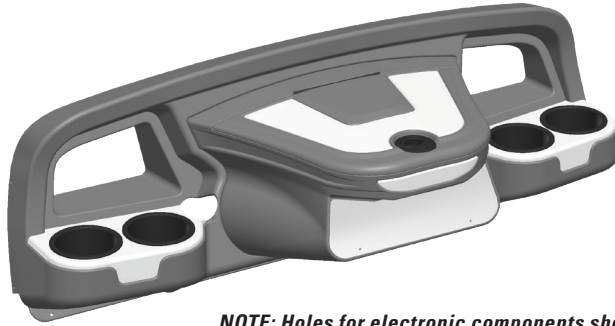

**NOTE:** Holes for electronic components should be cut out prior to mounting the dashboard. These cut out locations are at user's discretion.

### TABLE OF CONTENTS:

- Section 1** - Car Preparation
- Section 2** - Sentry Dash Installation
- Section 3** - Trim Kit Installation

**IMPORTANT:** Read through all instructions before beginning installation.

## CAR PREPARATION

### STEP 1.1 REMOVE FACTORY CUP HOLDER INSERT

Remove the plastic cup holder insert out of the dash, by unhooking the plastic factory clips under the bottom of the insert (A flat screw driver may be needed to pry it open).

### STEP 1.2 DISCONNECT COMPONENTS

Reach into dash thru the opening and disconnect all wiring from electronic components mounted to dash (The front body may be removed to make this easier.). Make sure to notate which wires go with which components, if there is more than one component (Ignition switch, Light switch, etc.).

### STEP 1.3 REMOVE ELECTRICAL COMPONENTS

Remove all electrical components from the factory dash. Set aside to be installed in Sentry Dash.

### STEP 1.4 ADD WIRING EXTENSIONS

Add 12" wire extensions to the wires of electrical components that need to be transferred to the face of the new dash.

### STEP 1.5 REMOVE STEERING WHEEL

Remove the center cap/scorecard holder from center of steering wheel. Remove large nut and pull steering wheel off of steering column shaft.

### E-Z-GO TXT / DOUBLETAKE PHOENIX-TX & TITAN

Car with factory components removed and ready for Sentry Dash installation

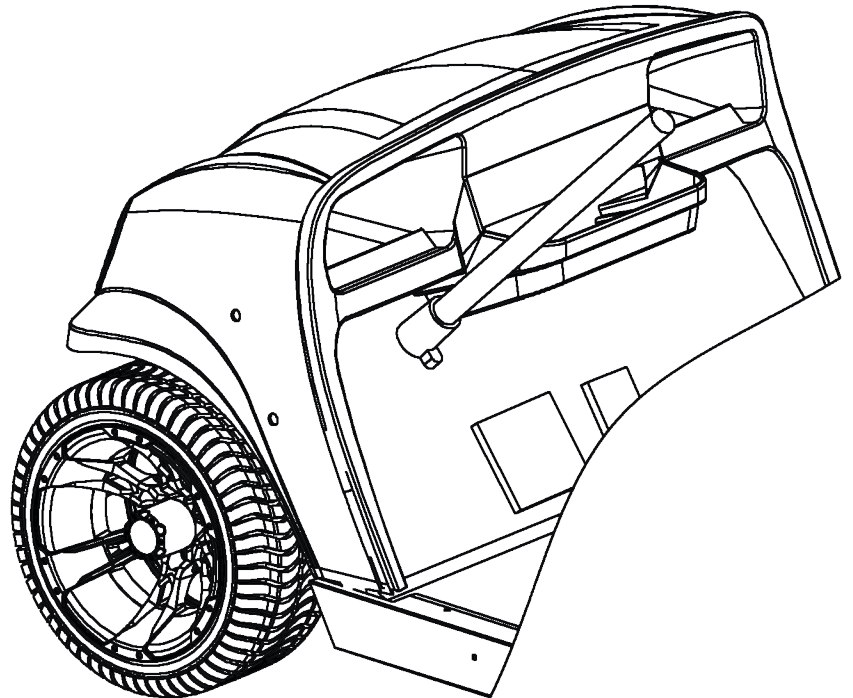

**NOTE:** Reattach the front body if removed in step 2.  
(Fasteners not provided.)

# SENTRY DASH INSTALLATION

## STEP 2.1 POSITION SENTRY DASH

Slide the Sentry Dash over the steering column (A), while pulling any wiring for electrical components through the lower outer openings (B).

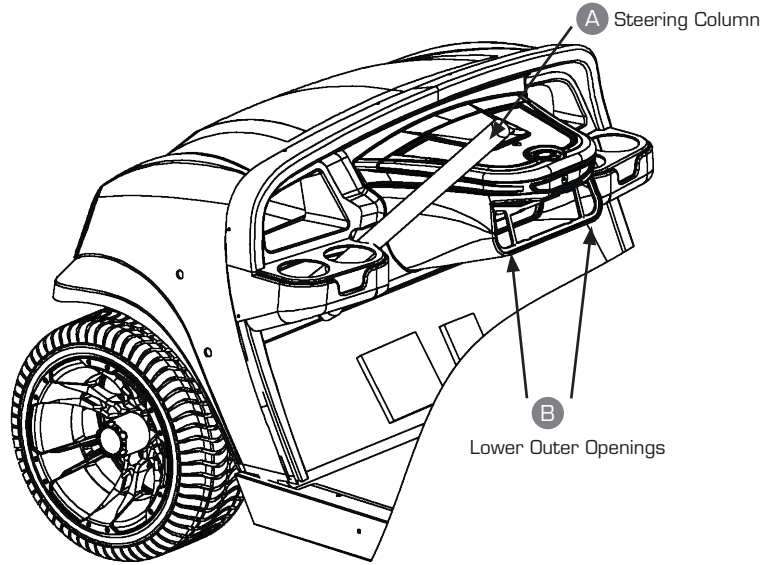

## STEP 2.2 ATTACH WITH SELF-TAPPING SCREWS

**Sentry Dash fits over existing factory dash cover.**

Once the dash is fully seated, align the front trimmed edge of the Sentry Dash with the front edge of the factory dash cover and screw the 8 self-tapping screws provided into the holes around the outside of the Sentry Dash (C).

Mounting holes located at the center bottom of the dashboard are optional (D).

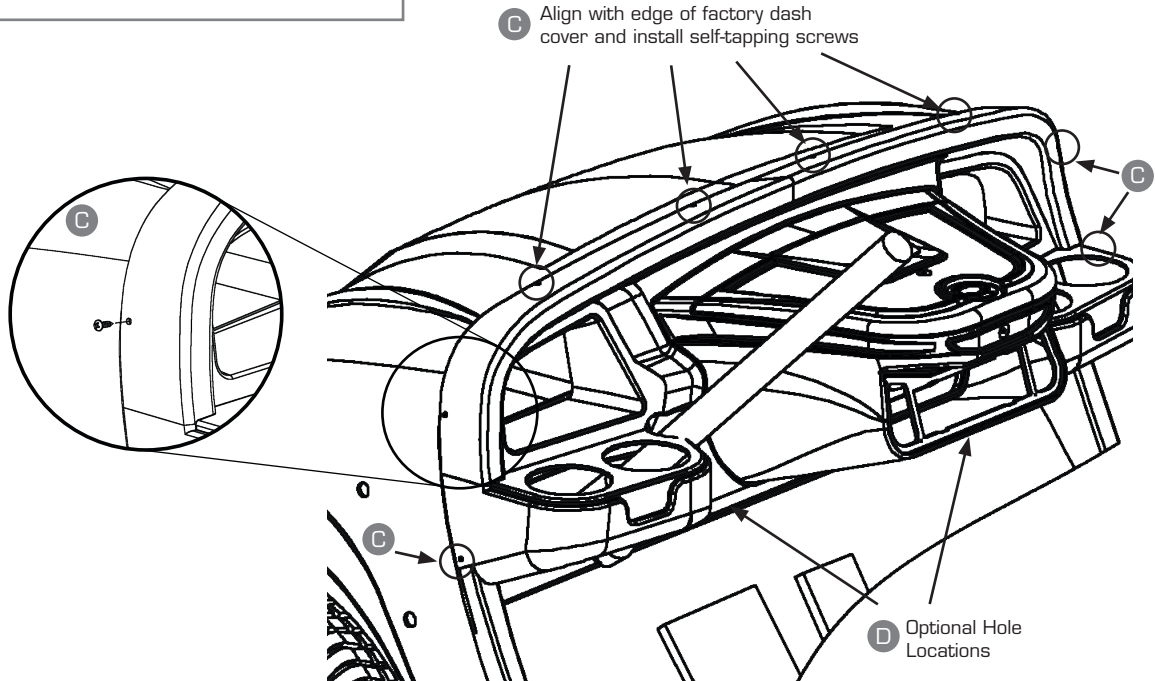

# TRIM KIT INSTALLATION

## STEP 3.1 INSTALL TRIM KIT

Remove protective film from outer surface of Cup Holder inserts (E). Attach inserts to Sentry Dash with peel and stick tape provided.

**NOTE: Items are left and right handed. Check for correct positioning before attaching with double-sided tape. The adhesive is automotive quality and may not be removeable without damage to the insert once applied.**

Place and press Cup Holders (F) into insert openings.

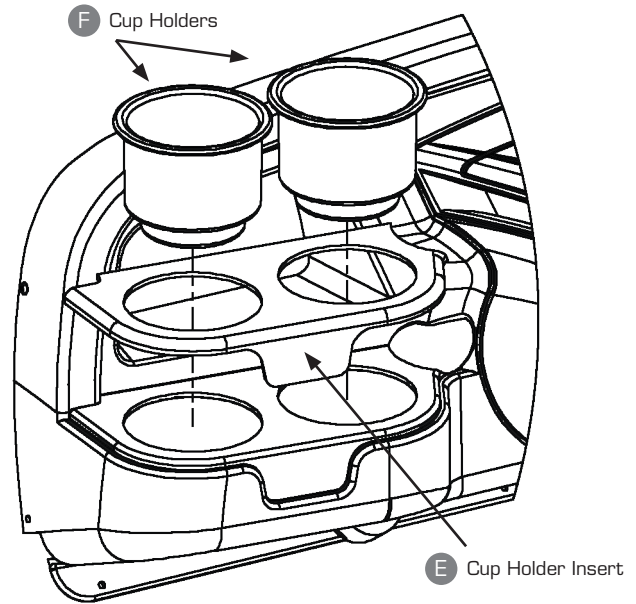

## STEP 3.2 ATTACH STORAGE AND NOSE INSERTS

Remove protective film from outer surface of Storage insert (G) and Nose insert (H). Then attach inserts to Sentry Dash with peel and stick tape provided.

## STEP 3.3 PREPARE FACEPLATE

Cut the necessary holes in the Faceplate insert (I) to install the electrical components that were taken out in section one. (Placement of these components varies by user). Install components and reconnect wiring.

## STEP 3.4 INSTALL FACEPLATE

Insert the Faceplate Tray and Faceplate insert into the lower dash opening and attach with the 4 small flat head screws provided.

## STEP 3.5 REATTACH STEERING WHEEL

Reattach the steering wheel to the steering column.

Installation is Complete.

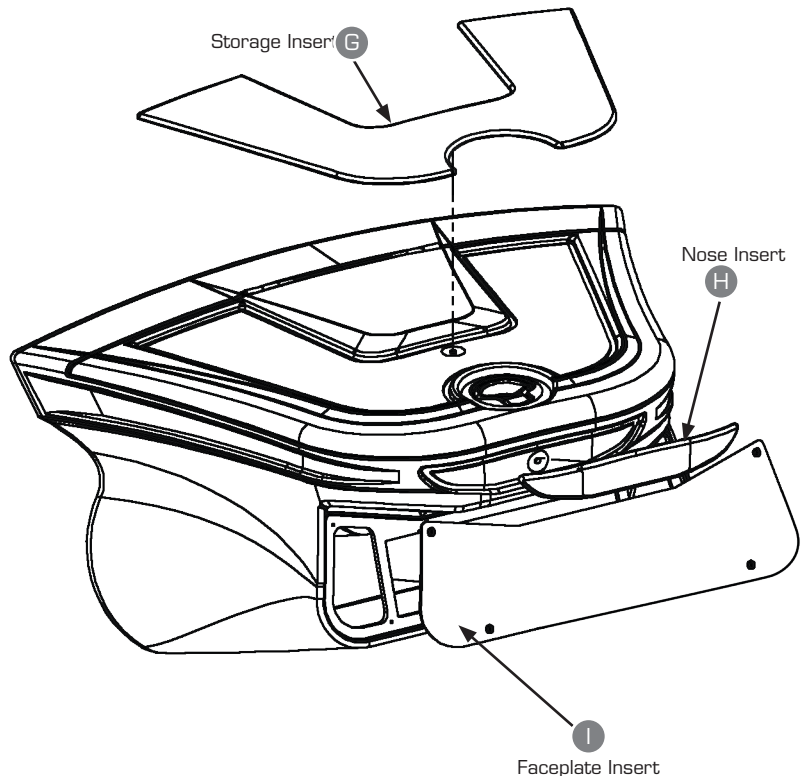



(This page left blank intentionally)